

Availability and specifications are determined regionally and are subject to change without notice. Please consult your authorised Toyota distributor for details. - Dentsu Production Concepts - 7207207850 - May 2006

Electric Powered Forklift 1.3 to 2.0 ton Series

7FBEF



VOLLEBREGT
BLEISWIJK

010 - 521 32 88

www.vorkheftrucks.nl



Strong, compact and versatile

Combining compact size and electric power, Toyota's 7FBEF forklift range is engineered to operate safely and effectively in a variety of work environments, including factories, warehouses and distribution centres.

Delivering safety, comfort, productivity and profitability, the 7FBEF range is available in five lifting capacities: 1.3, 1.5, 1.6, 1.8 and 2.0 tons. This wide range allows Toyota to deliver flexible solutions for a variety of needs, such as loading and unloading, internal transport of materials and the racking of goods.

Years of research and development have gone into designing the Toyota 7FBEF series to deliver safety, comfort and maximum productivity. Three key Toyota technologies – the System of Active Stability (SAS), the AC² Power System and the Operator Total Care (OTC) package – make the 7FBEF an excellent investment for a variety of professional applications.

Putting safety first

The Toyota 7FBEF range is equipped with the System of Active Stability (SAS), which ensures safe forklift use, reduces the risk of damaged goods and enhances overall workplace productivity.

Driving for comfort

Toyota's 7FBEF forklifts are designed with the operator in mind, from a low entry step for easy on/off access to the latest in ergonomic comfort. Toyota's Operator Total Care (OTC) package features easy-to-use controls and provides a comfortable working environment, allowing 7FBEF operators and their trucks to work more efficiently, day after day.

Turning power into productivity

The 7FBEF range also features the unique Toyota AC² Power System, which keeps trucks working at peak efficiency for longer periods of time. This system, which is common to all Toyota electric counterbalanced trucks, uses advanced technology to increase battery efficiency for enhanced reliability and maximal uptime.



TOYOTA
SAS
 System of Active Stability

Putting safety first

Safety is a top priority for forklift owners and operators. In addition to protecting people, investing in workplace safety also makes good business sense as it enhances productivity and reduces losses from damaged goods.

Toyota is a recognised leader in delivering the latest safety technology, including its System of Active Stability (SAS), which actively stabilises trucks and loads.

Maximum mast control

The 7FBFEF range is equipped with the SAS active mast control, which protects both drivers and loads when lifting, lowering, and tilting the mast.

Depending on the load weight and the height at which it is carried:

- Active Mast Front Tilt Angle Control automatically limits the forward tilt angle. This helps to prevent overloaded trucks from tipping and prevents loads from slipping off the forks.
- Active Mast Rear Tilt Speed Control limits the backward tilting speed, helping to prevent loose loads from dropping onto the driver's cabin.

Secure loading and unloading

Toyota Auto Fork Levelling protects goods against damage and ensures faster pallet handling. Drivers can place the forks in a perfectly horizontal position by pushing a button, thus simplifying loading and unloading.

Easy braking

The Accel-Off braking system reduces the time required to stop the truck, giving operators more time to react before having to engage the brake. Progressive braking force is automatically applied as soon as the operator's foot is lifted from the accelerator, delivering a more natural driving experience.

Driving position

The Active Steering Synchronizer constantly re-aligns the steering wheel with the rear wheel to deliver a safer, more comfortable driving experience.

Control on ramps

To protect operators, machinery and goods, the 7FBFEF range offers enhanced control when driving up ramps. An active system helps to prevent trucks from freewheeling backwards when the operator's foot is removed from the accelerator. The truck maintains its position momentarily until the operator can apply the handbrake.

Only a seated driver can operate the truck

Toyota's Operator Presence Sensing (OPS) determines whether an operator is seated. The truck will not drive, lift or lower the mast unless the operator is seated, thus protecting the truck from misuse.





Driving for comfort

The Toyota 7FBEF range includes the Toyota Operator Total Care (OTC) package, which enhances operator comfort and leads to improved productivity. Every aspect of the truck's design addresses operator needs, from easy truck access to ergonomically designed controls and a comfortable driver's seat.



Easy entry and exit

The Toyota 7FBEF range accommodates drivers who must constantly get on and off their trucks. A low step-in height and a conveniently located handgrip provide easy access for any driver. The uncluttered floor area and adjustable steering column allow operators to quickly assume a comfortable driving position that fits their individual needs.

Take a seat

With Toyota's Operator Restraint System (ORS) seat, drivers can select and maintain a comfortable position all day, every day. This four-way adjustable seat features lumbar support and a retractable seatbelt. Its carefully designed side wings offer back support to drivers when they turn to look over their shoulders while driving in reverse.

Ergonomic controls for material handling

The optimal configuration for materials handling levers varies according to operator preference and the materials handling task. To cater to this, Toyota offers the choice of either mini-lever controls or multifunction levers. These systems are built into the ergonomic seat-mounted armrest and allow operators to quickly and comfortably execute various materials handling functions, including lifting/lowering, tilting and side shift.

Mini-lever control

Up to four mini-levers deliver fingertip control for all material handling functions. For ease of operation, the forward and reverse directional control is also built into the armrest.

Multifunction levers

Twin multifunctional electronic levers allow the operator to carry out multiple functions with each lever. For example, lift/lower and tilt forwards/backwards functions are combined in one lever. The forward and reverse directional control is also built into the armrest.

Turning power into productivity

AC²

The 7FBEF range features Toyota's AC² Power System, which optimises battery efficiency to keep trucks working longer and harder. In addition, Toyota's easy battery exchange solutions maximise uptime for round-the-clock operations.

Intelligent AC power

The AC² Power System combines compact yet powerful AC motors with a sophisticated AC controller to deliver optimal control and power output. Every Toyota AC counterbalanced truck features the Power Select function, which allows operators to control the AC² Power System to maximum effect.

Power Select offers a choice of three different power modes: Standard, Power and High Power. Standard mode is designed for operations with slower materials handling speeds. The use of somewhat slower speeds ensures maximum operating time from the battery. Power mode and the even faster High Power mode offer quicker handling speeds than Standard mode but reduce the overall operating time for the battery.

A dashboard control allows the operator to select the desired Power Select mode. It is also possible to fine-tune the power settings further, depending on the needs of the operator and application.

One pedal to accelerate and brake

The Accel-Off braking system saves time and substantially improves productivity, particularly in confined and congested areas. Operators no longer need to constantly switch between accelerator and brake, as progressive braking force is automatically applied as soon as the operator's foot is lifted from the accelerator. There is a separate footbrake for emergency situations.

Regenerative braking

Toyota's Accel-Off braking system extends the operating time of the forklift by effectively converting the drive motor into a generator during braking and returning energy to the battery.

24-hour productivity

The Toyota 7FBEF range provides high performance and productivity over an entire shift. When trucks are required to work across multiple shifts, however, it may be necessary to exchange batteries. To this end, the 7FBEF offers two methods of battery exchange. The first method is Toyota's quick and easy horizontal battery exchange, where the battery is rolled off the truck sideways on rollers. The second method is the more traditional system of lifting the battery out of the truck's frame.

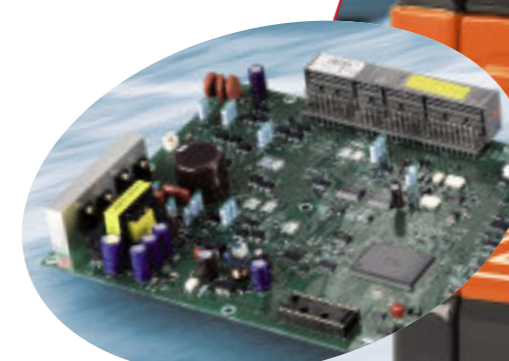



A profitable decision

Choosing a Toyota forklift from the 7FBEF range means investing in the best technology available. Like all Toyota trucks, the 7FBEF has been designed to enhance profitability for the user. Relentless attention to quality and durability in every detail ensures low life-cycle costs, making Toyota trucks a safe investment.

Profit from safe operation

A safe working environment is paramount for every member of a materials handling operation. The 7FBEF's SAS features provide for safe forklift operation and actively reduce the costs and risks of damage to goods and to the surrounding environment.

Profit from comfort

Toyota engineers have painstakingly crafted the Toyota 7FBEF range with the operator in mind. The truck's distinctive features ensure maximum operator comfort, resulting in enhanced productivity.

Profit from increased productivity

Toyota AC² technology makes the 7FBEF range more productive, reliable and energy efficient, and less costly to operate.

Profit from Toyota quality in every detail

Toyota's commitment to quality in design, component selection and manufacture ensures reliability on all levels. The dependability of Toyota's product line, coupled with expert after-sale service, helps maintain the peak performance of your materials handling process, day after day and year after year.

TOYOTA 7FBEF Range Outline

THE TOYOTA 7FBEF RANGE is available in five lifting capacities: 1.3 ton, 1.5 ton, 1.6 ton, 1.8 ton and 2.0 ton. With lift heights of up to 6 metres on all five versions, the Toyota 7FBEF range is ideal for applications requiring compact size and high lift-height capabilities.

These powerful 48-volt trucks provide enhanced material handling speed and power. Easy battery change methods are available to facilitate multiple-shift operations.

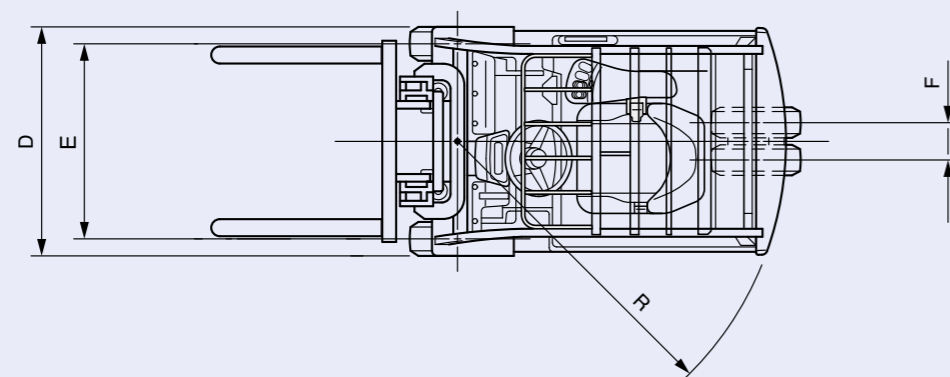
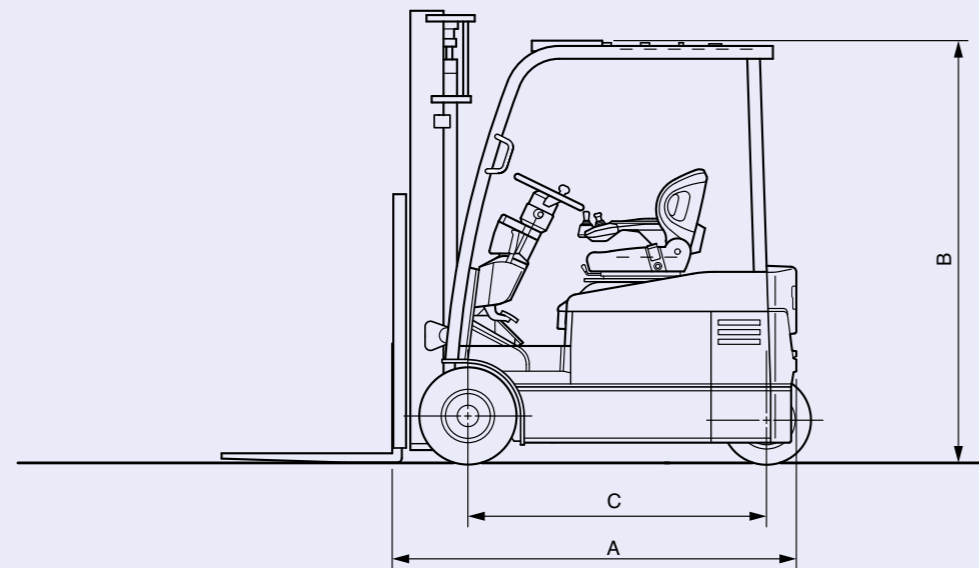

7FBEF15



7FBEF20



MODEL		7FBEF 13	7FBEF 15	7FBEF 16	7FBEF 18	7FBEF 20
Load capacity	(kg)	1250	1500	1600	1800	2000
Load center	(mm)	500	500	500	500	500
Standard fork height	(mm)	3300	3300	3300	3300	3300
Travel speed	Full load	15	15	15	14.5	14
	No load	16.5	16.5	16	16	15.5
Lifting speed	Full load	450	430	420	390	340
	No load	610	610	610	610	500
Turning radius	R	1400	1540	1640	1645	1710
Length to fork face	A	1760	1895	1995	2000	2080
Overhead guard height	B	1980	1980	1980	1980	1980
Wheelbase	C	1210	1400	1505	1505	1505
Overall width	D	1070	1070	1070	1070	1125
Tread front	E	915	915	915	915	915
Tread rear	F	175	175	175	175	205



Toyota. Share our strength

As the world leader in materials handling, Toyota is uniquely placed to offer solutions for all of your materials handling needs. By investing heavily in new engineering technologies and manufacturing techniques, we aim to bring you the most productive products available. By constantly expanding our sales, distribution and after-sales service network, we ensure a fast, effective response to your requirements.

A global presence

Production facilities in Japan, the United States and Europe are supported by a sales and supply network covering 170 countries to offer Toyota customers quick, comprehensive support around the world.

A European resource

Over the years, Toyota has developed a strong European presence, establishing close geographic links with its customers in order to better understand and satisfy their needs. Our three European manufacturing facilities are located in France, Sweden and Italy.

The 35,000m² facility in Ancenis, France employs 330 people, producing internal combustion (IC) and electric forklifts for the European market. The factory in Mjölby, Sweden employs more than 1,400 people. At 76,000m², it is one of the largest warehouse equipment manufacturing facilities in the world. The 67,000m² site in Bologna, Italy employs 330 people and produces electric powered forklifts.

Service Network

Our extensive parts and service network in Europe provides Toyota service locations with instant access to a permanent stock of more than 70,000 spare parts. Our service engineers receive thorough and ongoing training, and offer an unparalleled level of expertise and coverage across Europe.

Research & Development

Toyota Industrial Equipment benefits from Toyota's vast experience in the automotive industry, especially in engine development. By taking full advantage of the group's massive R&D facilities and engineering expertise, Toyota has developed a number of world-class technologies. Intelligent use of electronic and computer-controlled devices has also contributed significantly to the creation of more ergonomic and user-friendly operator environments.