

# Elektrische Vorkheftrucks 1.8 t

TOYOTA  
**TTRIGO<sup>48</sup>**

4 wiel



# Elektrische Vorkheftrucks 1.8 t

Specificaties						8FBMT18
Kenmerken	1.1	Fabrikant				TOYOTA
	1.2	Type				8FBMT18
	1.3	Aandrijving				Elektro
	1.4	Besturing				Zittend
	1.5	Hefvermogen		Q	kg	1800
	1.6	Bij lastzwaartepunt		c	mm	500
	1.8	Lastafstand		x	mm	358
	1.9	Wielbasis		y	mm	1530
	Gewicht	2.1	Eigen gewicht			
2.2		Asbelasting met last voor/achter				4420/513
2.3		Asbelasting zonder last voor/achter				1613/1520
Wielen en banden	3.1	Banden - Lucht (P), Volrubber (SE), Cushion (R)				SE
	3.2	Bandenmaat voor				18x7-8
	3.3	Bandenmaat achter				16x6-8
	3.5	Wielen, aantal voor/achter (x = aangedreven)				2x/2
	3.6	Spoorbreedte voor		b <sub>10</sub>	mm	894
	3.7	Spoorbreedte achter		b <sub>11</sub>	mm	880
	Afmetingen	4.1	Neiging mast/voorover/achterover		$\alpha/\beta$	deg
4.2		Bouwhoogte, mast ingeschoven		h <sub>1</sub>	mm	2120
4.3		Vrije heffing		h <sub>2</sub>	mm	115
4.4		Hefbeweging		h <sub>3</sub>	mm	3265
		Hefhoogte		h <sub>23</sub>	mm	3300
4.5		Hoogte, mast in hoogste stand		h <sub>4</sub>	mm	3870
4.7		Hoogte beschermdak (cabine)		h <sub>6</sub>	mm	2055
4.8		Zithoogte		h <sub>7</sub>	mm	944
4.12		Hoogte trekpen		h <sub>10</sub>	mm	427
4.19		Totale lengte		l <sub>1</sub>	mm	3188
4.20		Lengte incl. vorkrug		l <sub>2</sub>	mm	2188
4.21		Totale breedte		b <sub>1</sub>	mm	1050
4.22		Vorkafmetingen		s/e/l	mm	35/100/1000
4.23		Vorkenbord DIN 15173, klasse/type A, B				A
4.24		Breedte vorkenbord		b <sub>3</sub>	mm	920
4.31		Bodemvrijheid belast, onderkant mast		m <sub>1</sub>	mm	80
4.32		Bodemvrijheid midden wielbasis		m <sub>2</sub>	mm	101
4.33		Gangpadbreedte bij pallets 1000 x 1200 dwars		A <sub>st</sub>	mm	3465
4.34	Gangpadbreedte bij pallets 800 x 1200 langs		A <sub>st</sub>	mm	3618	
4.35	Draaistraal		W <sub>a</sub>	mm	1845	
4.36	Binnenstraal		b <sub>13</sub>	mm	186	
Prestaties	5.1	Rijsnelheid met/zonder last			km/h	20/20
	5.2	Hefsnelheid met/zonder last			m/s	0,42/0,61
	5.3	Daalsnelheid met/zonder last			m/s	0,53/0,55
	5.5	Trekkkracht met/zonder last			N	4998/5143
	5.6	Maximale trekkkracht met/zonder last			N	9448/9409
	5.7	Klimvermogen met/zonder last			%	15,3/24,2
	5.8	Maximaal klimvermogen met/zonder last			%	21,0/24,2
5.10	Bedrijfsrem				Mechanisch	
Motor	6.1	Rijmotorvermogen S2 60 min			kW	6,6x2
	6.2	Pompmotorvermogen bij S3 15%			kW	11
	6.3	Batterij volgens DIN 43531/35/36 A, B, C, nee				43 531A
	6.4	Batterijspanning/batterijcapaciteit K <sub>5</sub>			V/Ah	48/660
	6.5	Batterijgewicht			kg	1013
Andere	8.1	Aandrijving				MOSFET
	8.2	Werkdruk voor aanbouwapparatuur			bar	183
	8.3	Olie voor aanbouwapparatuur			l/min	41,3
	8.4	Geluidsniveau op oorhoogte chauffeur, soort EN 12 053			dB(A)	70,7

De prestaties en afmetingen van de truck zijn gebaseerd op nominale waarden. Hierop zijn enige afwijkingen mogelijk. De producten van Toyota en de technische gegevens van de producten kunnen zonder voorafgaand bericht worden gewijzigd.

# Mastspecificaties and restcapaciteit

Model		V								FV				FW				FSV						FSW								
8FBMT15/16/18/20	Hefhoogte	$h_{23}$	3000	3300	3500	3700	4000	4500	5000	3000	3300	3500	3700	3000	3300	3500	3700	4300	4500	4700	5000	5500	6000	4300	4500	4700	5000	5500	6000	6500	7000	7500
	Hefbeweging	$h_3$	2965	3265	3465	3665	3965	4465	4965	2965	3265	3465	3665	2965	3265	3465	3665	4265	4465	4665	4965	5465	5965	4265	4465	4665	4965	5465	5965	6465	6965	7465
	Masthoogte, mast ingeschoven	$h_1$	1970	2120	2220	2380	2570	2820	3070	1970	2120	2220	2380	2000	2150	2250	2350	1970	2040	2120	2220	2380	2570	1980	2050	2150	2250	2450	2600	2800	3000	3200
	Masthoogte, mast in hoogste stand <sup>1)</sup>	$h_1$	3570	3870	4070	4270	4570	5070	5570	3580	3880	4080	4280	3555	3855	4055	4255	4845	5045	5245	5545	6045	6545	4845	5045	5245	5545	6045	6545	7045	7545	8045
	Masthoogte, mast in hoogste stand <sup>2)</sup>	$h_1$	4260	4560	4760	4960	5260	5760	6260	4260	4560	4760	4960	4260	4560	4760	4960	5560	5760	5960	6260	6760	7260	5560	5760	5960	6260	6760	7260	7760	8260	8760
	Vrije heffing, zonder lastrek	$h_2$	115	115	115	115	115	115	115	1425	1575	1675	1835	1485	1635	1735	1835	1450	1520	1600	1700	1860	2050	1475	1545	1645	1745	1945	2095	2295	2495	2695
Vrije heffing, met lastrek	$h_2$	115	115	115	115	115	115	115	745	895	995	1155	780	930	1030	1130	745	815	895	995	1155	1345	760	830	930	1030	1230	1380	1580	1780	1980	

1) Zonder lastrek.

2) Met lastrek; Hoogte standaard lastrek is 1220 mm.

Volrubberband		V								FV				FW				FSV						FSW							
8FBMT15	Neelhoek, voorw.	deg	5	5	5	5	5	5	5	5	5	5	5	5	5	5	5	5	5	5	5	5	5	5	5	5	5	5	5	5	5
	Neelhoek, achterw.	deg	7(5)	7(5)	7(5)	7(5)	7(5)	7(5)	7(5)	7(5)	7(5)	7(5)	7(5)	7(5)	7(5)	7(5)	7(5)	7(5)	7(5)	7(5)	7(5)	7(5)	7(5)	7(5)	7(5)	7(5)	7(5)	7(5)	7(5)	7(5)	7(5)
	Hefvermogen op 500 mm LC	kg	1500	1500	1500	1500	1500	1450	1350	1500	1500	1500	1500	1500	1500	1500	1500	1450	1450	1400	1400	1250	1100	1450	1450	1400	1400	1250	1100	900	850
8FBMT16	Neelhoek, voorw.	deg	5	5	5	5	5	5	5	5	5	5	5	5	5	5	5	5	5	5	5	5	5	5	5	5	5	5	5	5	5
	Neelhoek, achterw.	deg	7(5)	7(5)	7(5)	7(5)	7(5)	7(5)	7(5)	7(5)	7(5)	7(5)	7(5)	7(5)	7(5)	7(5)	7(5)	7(5)	7(5)	7(5)	7(5)	7(5)	7(5)	7(5)	7(5)	7(5)	7(5)	7(5)	7(5)	7(5)	7(5)
	Hefvermogen op 500 mm LC	kg	1600	1600	1600	1600	1600	1550	1450	1600	1600	1600	1600	1600	1600	1600	1600	1550	1550	1500	1450	1350	1200	1550	1550	1500	1450	1350	1200	1050	900
8FBMT18	Neelhoek, voorw.	deg	5	5	5	5	5	5	5	5	5	5	5	5	5	5	5	5	5	5	5	5	5	5	5	5	5	5	5	5	5
	Neelhoek, achterw.	deg	7(5)	7(5)	7(5)	7(5)	7(5)	7(5)	7(5)	7(5)	7(5)	7(5)	7(5)	7(5)	7(5)	7(5)	7(5)	7(5)	7(5)	7(5)	7(5)	7(5)	7(5)	7(5)	7(5)	7(5)	7(5)	7(5)	7(5)	7(5)	7(5)
	Hefvermogen op 500 mm LC	kg	1800	1800	1800	1800	1800	1750	1650	1800	1800	1800	1800	1800	1800	1800	1800	1700	1700	1600	1600	1450	1250	1700	1700	1600	1600	1450	1250	1100	950
8FBMT20	Neelhoek, voorw.	deg	5	5	5	5	5	5	5	5	5	5	5	5	5	5	5	5	5	5	5	5	5	5	5	5	5	5	5	5	5
	Neelhoek, achterw.	deg	7(5)	7(5)	7(5)	7(5)	7(5)	7(5)	7(5)	7(5)	7(5)	7(5)	7(5)	7(5)	7(5)	7(5)	7(5)	7(5)	7(5)	7(5)	7(5)	7(5)	7(5)	7(5)	7(5)	7(5)	7(5)	7(5)	7(5)	7(5)	7(5)
	Hefvermogen op 500 mm LC	kg	2000	2000	2000	2000	2000	1900	1750	2000	2000	2000	2000	2000	2000	2000	2000	1850	1850	1800	1700	1500	1300	1850	1850	1800	1700	1500	1300	1150	1000

Luchtbanden		V								FV				FW				FSV						FSW							
8FBMT15	Neelhoek, voorw.	deg	5	5	5	5	5	5	5	5	5	5	5	5	5	5	5	5	5	5	5	5	5	5	5	5	5	5	5	5	5
	Neelhoek, achterw.	deg	7(5)	7(5)	7(5)	7(5)	7(5)	7(5)	7(5)	7(5)	7(5)	7(5)	7(5)	7(5)	7(5)	7(5)	7(5)	7(5)	7(5)	7(5)	7(5)	7(5)	7(5)	7(5)	7(5)	7(5)	7(5)	7(5)	7(5)	7(5)	7(5)
	Hefvermogen op 500 mm LC	kg	1500	1500	1500	1500	1500	1450	1350	1500	1500	1500	1500	1500	1500	1500	1500	1400	1380	1350	1200	1100	900	1400	1380	1350	1200	1100	900	800	700
8FBMT16	Neelhoek, voorw.	deg	5	5	5	5	5	5	5	5	5	5	5	5	5	5	5	5	5	5	5	5	5	5	5	5	5	5	5	5	5
	Neelhoek, achterw.	deg	7(5)	7(5)	7(5)	7(5)	7(5)	7(5)	7(5)	7(5)	7(5)	7(5)	7(5)	7(5)	7(5)	7(5)	7(5)	7(5)	7(5)	7(5)	7(5)	7(5)	7(5)	7(5)	7(5)	7(5)	7(5)	7(5)	7(5)	7(5)	7(5)
	Hefvermogen op 500 mm LC	kg	1600	1600	1600	1600	1600	1550	1450	1600	1600	1600	1600	1600	1600	1600	1600	1500	1450	1450	1300	1200	1000	1500	1450	1450	1300	1200	1000	9200	800
8FBMT18	Neelhoek, voorw.	deg	5	5	5	5	5	5	5	5	5	5	5	5	5	5	5	5	5	5	5	5	5	5	5	5	5	5	5	5	5
	Neelhoek, achterw.	deg	7(5)	7(5)	7(5)	7(5)	7(5)	7(5)	7(5)	7(5)	7(5)	7(5)	7(5)	7(5)	7(5)	7(5)	7(5)	7(5)	7(5)	7(5)	7(5)	7(5)	7(5)	7(5)	7(5)	7(5)	7(5)	7(5)	7(5)	7(5)	7(5)
	Hefvermogen op 500 mm LC	kg	1800	1800	1800	1800	1800	1750	1650	1800	1800	1800	1800	1800	1800	1800	1800	1600	1580	1550	1350	1250	1050	1600	1580	1550	1350	1250	1050	950	850

Data tussen ( ) zijn wanneer cabine optie (type, minimaal voorruit) is geselecteerd

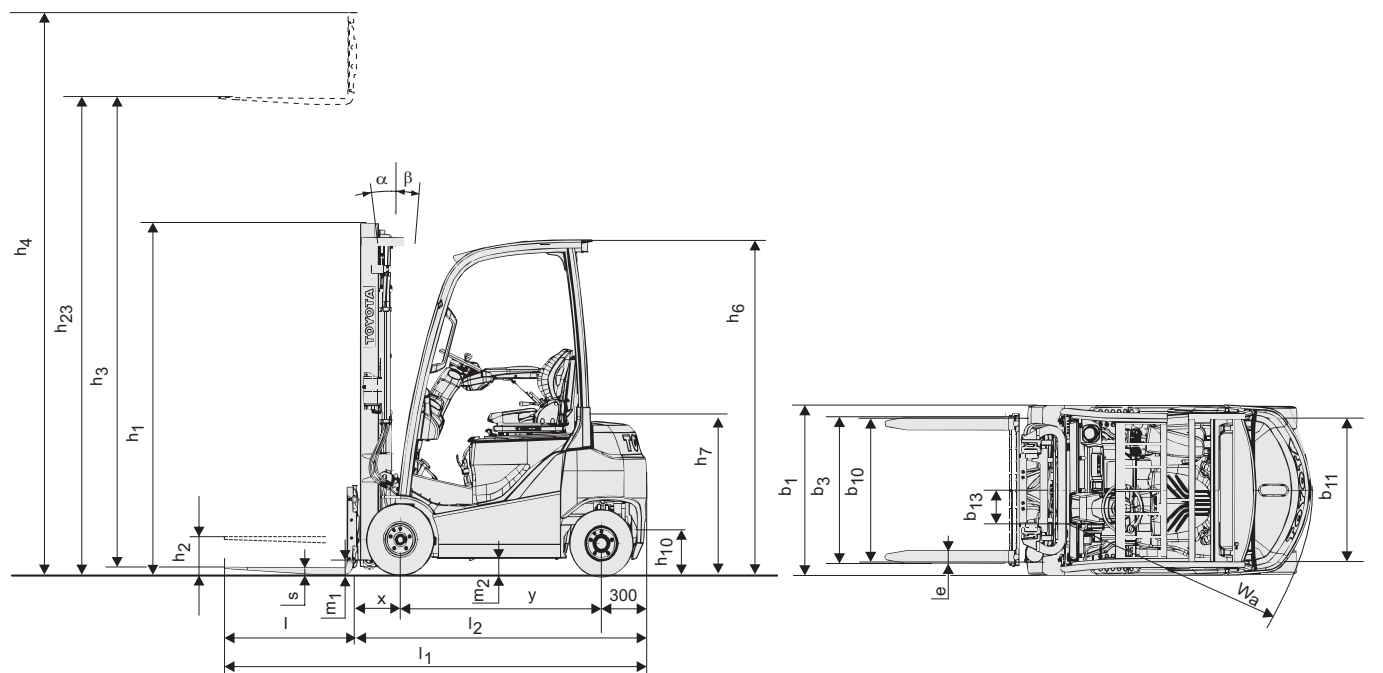

## Standaard uitrusting

- Toyota SAS (Systeem van Actieve Stabiliteit)
- Toyota AC<sup>2</sup> Systeem
- Toyota ORS stoel (Operator Restraint System)
- Aan stoel gemonteerde armsteun met minilevers
- Doorkijkmast (Hefhoogte:3300)
- Lange vorken (Lengte:1000mm)
- Breder vorkenbord (Breedte: 920mm)
- 3<sup>e</sup> Stuurventiel
- Oliebadremmen
- Volrubberbanden
- Volledig hydraulische stuurbevestiging
- Digitaal multifunctioneel display met wielstandindicatie
- Verstelbare stuurkolom met geheugen

  
**VOLLEBREGT**  
BLEISWIJK

010 - 521 32 88

[www.vorkheftrucks.nl](http://www.vorkheftrucks.nl)

**TOYOTA**

MATERIAL HANDLING

stronger together