

Elektrische Vorkheftrucks 1.5 t

TOYOTA
TRIGO⁴⁸

3 wiel



Elektrische Vorkheftrucks 1.5 t

Specificaties					8FBET15
Kenmerken	1.1	Fabrikant			TOYOTA
	1.2	Type			8FBET15
	1.3	Aandrijving			Elektro
	1.4	Besturing			Zittend
	1.5	Hefvermogen	Q	kg	1500
	1.6	Bij lastzwaartepunt	c	mm	500
	1.8	Lastafstand	x	mm	358
	1.9	Wielbasis	y	mm	1264
	Gewicht	2.1	Eigen gewicht		kg
2.2		Asbelasting met last voor/achter		kg	3991/543
2.3		Asbelasting zonder last voor/achter		kg	1485/1550
Wielen en banden	3.1	Banden - Lucht (P), Volrubber (SE), Cushion (R)			SE
	3.2	Bandenmaat voor			18x7-8
	3.3	Bandenmaat achter			15x4.1/2x8
	3.5	Wielen, aantal voor/achter (x = aangedreven)			2x/2
	3.6	Spoorbreedte voor	b ₁₀	mm	894
	3.7	Spoorbreedte achter	b ₁₁	mm	175,4
	Afmetingen	4.1	Neiging mast/voorover/achterover	α/β	deg
4.2		Bouwhoogte, mast ingeschoven	h ₁	mm	2120
4.3		Vrije heffing	h ₂	mm	115
4.4		Hefbeweging	h ₃	mm	3265
		Hefhoogte	h ₂₃	mm	3300
4.5		Hoogte, mast in hoogste stand	h ₄	mm	3870
4.7		Hoogte beschermdak (cabine)	h ₆	mm	2055
4.8		Zithoogte	h ₇	mm	944
4.12		Hoogte trekpen	h ₁₀	mm	537
4.19		Totale lengte	l ₁	mm	2792
4.20		Lengte incl. vorkrug	l ₂	mm	1792
4.21		Totale breedte	b ₁	mm	1050
4.22		Vorkafmetingen	s/e/l	mm	35/100/1000
4.23		Vorkenbord DIN 15173, klasse/type A, B			IIA
4.24		Breedte vorkenbord	b ₃	mm	920
4.31		Bodemvrijheid belast, onderkant mast	m ₁	mm	80
4.32		Bodemvrijheid midden wielbasis	m ₂	mm	90
4.33		Gangpadbreedte bij pallets 1000 x 1200 dwars	A _{st}	mm	3119
4.34	Gangpadbreedte bij pallets 800 x 1200 langs	A _{st}	mm	3243	
4.35	Draaistraal	W _a	mm	1434	
4.36	Binnenstraal	b ₁₃	mm	0	
Prestaties	5.1	Rijsnelheid met/zonder last		km/h	16/16
	5.2	Hefsnelheid met/zonder last		m/s	0,44/0,61
	5.3	Daalsnelheid met/zonder last		m/s	0,53/0,55
	5.5	Trekkracht met/zonder last		N	5068/5158
	5.6	Maximale trekkracht met/zonder last		N	9519/9424
	5.7	Klimvermogen met/zonder last		%	16,9/22,0
5.8	Maximaal klimvermogen met/zonder last		%	23,1/22,00	
5.10	Bedrijfsrem			Mechanisch	
Motor	6.1	Rijmotorvermogen S2 60 min		kW	6,6x2
	6.2	Pompmotorvermogen bij S3 15%		kW	11
	6.3	Batterij volgens DIN 43531/35/36 A, B, C, nee			43 531A
	6.4	Batterijspanning/batterijcapaciteit K _s		V/Ah	48/440
	6.5	Batterijgewicht		kg	708
Andere	8.1	Aandrijving			MOSFET
	8.2	Werkdruk voor aanbouwapparatuur		bar	183
	8.3	Olie voor aanbouwapparatuur		l/min	41,3
	8.4	Geluidsniveau op oorhoogte chauffeur, soort EN 12 053		dB(A)	70,7

De prestaties en afmetingen van de truck zijn gebaseerd op nominale waarden. Hierop zijn enige afwijkingen mogelijk. De producten van Toyota en de technische gegevens van de producten kunnen zonder voorafgaand bericht worden gewijzigd.

Mastspecificaties and restcapaciteit

Model		V								FV				FW				FSV					FSW									
8FBET15/8FBET16 /8FBET16	Hefhoogte	h_{23}	3000	3300	3500	3700	4000	4500	5000	3000	3300	3500	3700	3000	3300	3500	3700	4300	4500	4700	5000	5500	6000	4300	4500	4700	5000	5500	6000	6500	7000	7500
	Hefbeweging	h_3	2965	3265	3465	3665	3965	4465	4965	2965	3265	3465	3665	2965	3265	3465	3665	4265	4465	4665	4965	5465	5965	4265	4465	4665	4965	5465	5965	6465	6965	7465
	Masthoogte, mast ingeschoven	h_1	1970	2120	2220	2380	2570	2820	3070	1970	2120	2220	2380	2000	2150	2250	2350	1970	2040	2120	2220	2380	2570	1980	2050	2150	2250	2450	2600	2800	3000	3200
	Masthoogte, mast in hoogste stand ¹⁾	h_4	3570	3870	4070	4270	4570	5070	5570	3580	3880	4080	4280	3555	3855	4055	4255	4845	5045	5245	5545	6045	6545	4845	5045	5245	5545	6045	6545	7045	7545	8045
	Masthoogte, mast in hoogste stand ²⁾	h_4	4260	4560	4760	4960	5260	5760	6260	4260	4560	4760	4960	4260	4560	4760	4960	5560	5760	5960	6260	6760	7260	5560	5760	5960	6260	6760	7260	7760	8260	8760
	Vrije heffing, zonder lastrek	h_2	115	115	115	115	115	115	115	1425	1575	1675	1835	1485	1635	1735	1835	1450	1520	1600	1700	1860	2050	1475	1545	1645	1745	1945	2095	2295	2495	2695
Vrije heffing, met lastrek	h_2	115	115	115	115	115	115	115	745	895	995	1155	780	930	1030	1130	745	815	895	995	1155	1345	760	830	930	1030	1230	1380	1580	1780	1980	

1) Zonder lastrek.

2) Met lastrek; Hoogte standaard lastrek is 1220 mm.

Volrubberband		V								FV				FW				FSV					FSW									
8FBET15 /8FBET16	Neighoek, voorw.	deg	5	5	5	5	5	5	5	5	5	5	5	5	5	5	5	5	5	5	5	5	5	5	5	5	5	5	5	5	5	5
	Neighoek, achterw.	deg	7(5)	7(5)	7(5)	7(5)	7(5)	7(5)	7(5)	7(5)	7(5)	7(5)	7(5)	7(5)	7(5)	7(5)	7(5)	7(5)	7(5)	7(5)	7(5)	7(5)	7(5)	7(5)	7(5)	7(5)	7(5)	7(5)	7(5)	7(5)	7(5)	7(5)
	Hefvermogen op 500 mm LC	kg	1500	1500	1500	1500	1500	1500	1450	1500	1500	1500	1500	1500	1500	1500	1500	1450	1430	1420	1380	1320	1200	1450	1430	1420	1380	1320	1200	900	650	400
8FBET16 /8FBET16	Neighoek, voorw.	deg	5	5	5	5	5	5	5	5	5	5	5	5	5	5	5	5	5	5	5	5	5	5	5	5	5	5	5	5	5	5
	Neighoek, achterw.	deg	7(5)	7(5)	7(5)	7(5)	7(5)	7(5)	7(5)	7(5)	7(5)	7(5)	7(5)	7(5)	7(5)	7(5)	7(5)	7(5)	7(5)	7(5)	7(5)	7(5)	7(5)	7(5)	7(5)	7(5)	7(5)	7(5)	7(5)	7(5)	7(5)	7(5)
	Hefvermogen op 500 mm LC	kg	1600	1600	1600	1600	1600	1600	1550	1600	1600	1600	1600	1600	1600	1600	1600	1550	1500	1450	1400	1350	1300	1550	1500	1450	1400	1350	1300	1000	750	500

Luchtbanden		V								FV				FW				FSV					FSW									
8FBET15 /8FBET16	Neighoek, voorw.	deg	5	5	5	5	5	5	5	5	5	5	5	5	5	5	5	5	5	5	5	5	5	5	5	5	5	5	5	5	5	5
	Neighoek, achterw.	deg	7(5)	7(5)	7(5)	7(5)	7(5)	7(5)	7(5)	7(5)	7(5)	7(5)	7(5)	7(5)	7(5)	7(5)	7(5)	7(5)	7(5)	7(5)	7(5)	7(5)	7(5)	7(5)	7(5)	7(5)	7(5)	7(5)	7(5)	7(5)	7(5)	7(5)
	Hefvermogen op 500 mm LC	kg	1500	1500	1500	1500	1450	1350	1250	1500	1500	1500	1500	1500	1500	1500	1500	1400	1370	1350	1200	900	700	1400	1370	1350	1200	900	700	550	400	300
8FBET16 /8FBET16	Neighoek, voorw.	deg	5	5	5	5	5	5	5	5	5	5	5	5	5	5	5	5	5	5	5	5	5	5	5	5	5	5	5	5	5	5
	Neighoek, achterw.	deg	7(5)	7(5)	7(5)	7(5)	7(5)	7(5)	7(5)	7(5)	7(5)	7(5)	7(5)	7(5)	7(5)	7(5)	7(5)	7(5)	7(5)	7(5)	7(5)	7(5)	7(5)	7(5)	7(5)	7(5)	7(5)	7(5)	7(5)	7(5)	7(5)	7(5)
	Hefvermogen op 500 mm LC	kg	1600	1600	1600	1600	1550	1500	1400	1600	1600	1600	1600	1600	1600	1600	1600	1450	1420	1400	1300	950	750	1450	1420	1400	1300	950	750	600	450	350

Data tussen () zijn wanneer cabine optie (type, minimaal voorruit) is geselecteerd.

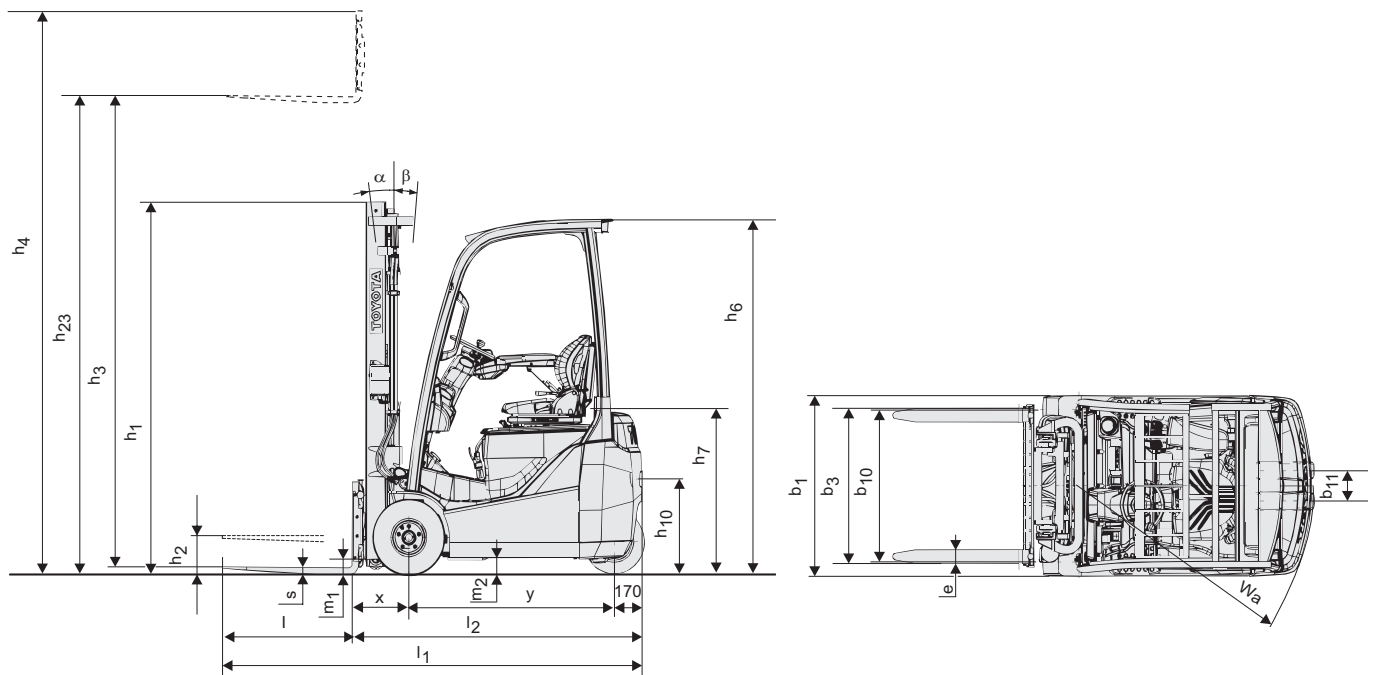

Standaard uitrusting

- Toyota SAS (Systeem van Actieve Stabiliteit)
- Toyota AC² Systeem
- Toyota ORS stoel (Operator Restraint System)
- Aan stoel gemonteerde armsteun met minilevers
- Doorkijkmast (Hefhoogte:3300)
- Lange vorken (Lengte:1000mm)
- Breder vorkenbord (Breedte: 920mm)
- 3^e Stuurventiel
- Oliebadremmen
- Volrubberbanden
- Volledig hydraulische stuurbekrachtiging
- Digitaal multifunctioneel display met wielstandindicatie
- Verstelbare stuurkolom met geheugen

VOLLEBREGT
BLEISWIJK

010 - 521 32 88

www.vorkheftrucks.nl

TOYOTA

MATERIAL HANDLING

stronger together